

DIMENSIONS

All dimensions are approximate. Dimensions may vary with bucket and tire choice. Refer to operating specifications.

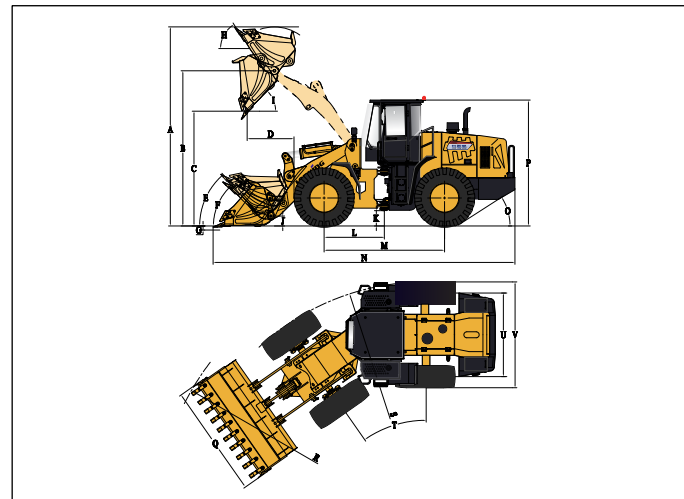

NO.	DESCRIPTION	UNIT	STD	High Dump
A	Overall Height - Bucket Raised	mm	4737	5080
B	Bucket Pin Height at Max. Lift	mm	3710	4064
C	Dump Clearance at Max. Lift (45°)	mm	2904	3249
D	Reach at Max. Lift and 45° Dump	mm	1095	1002
E	Rack Back Angle at Carry	°	46.3	46.6
F	Rack Back Angle at Ground	°	40	40.9
G	Digging Depth	mm	30-40	30-40
H	Rack Back Angle at Max. Lift	°	50.7	47
I	Dump Angle at Max. Lift	°	46.6	45
J	Carry Height	mm	400	400
K	Ground Clearance	mm	345	345
L	Center Line of Front Axle to Hitch	mm	1425	1425
M	Wheel Base	mm	2850	2850
N	Overall Length	mm	7200	7450
O	Departure Angle	°	27	27
P	Height to Top of Cab	mm	3180	3180
Q	Overall Width over Bucket	mm	2500	2500
R	Min. Turning Radius over Bucket	mm	6190	6280
S	Min. Turning Radius over Tires	mm	5675	5675
T	Steering Angle - Left/Right	°	35	35
U	Width at Tread Center	mm	1850	1850
V	Overall Width over Tires	mm	2320	2320

OVERALL DATA

Bucket Capacity	1.7m	1.7m
Rated Payload	3000kg	3000kg
Operating Weight	10300±300kg	10500±300kg
Traction Force	97±3kN	97±3kN
Breakout Force	105±3kN	95±3kN
LWH(mm)	7200/2500/3180	7450/2500/3180

ENGINE & ELECTRICAL SYSTEM

Maker/Model	WEICHAI/WP6G125E22
Emission Standard	National 4
Engine Type	4 Stroke Turbocharged Water-cooled Direct Injection Diesel Engine
Rated Power	92kW (125hp) / 2200rpm
Maximum Torque	500N·m / 1400-1600rpm
Bore x Stroke (mm)	105/130
No. of Cylinders/Displacement	6/6.75L
Compression Ratio	18.0
Air Cleaner	Three Stage Air Cleaner
Alternator	55Amp
Battery	2-24V/105Ah
Starting Motor	24V/6kW
Heating Capacity (W)	5000W

DRIVETRAIN

Transmission Type	Countershaft Powershift Transmission			
Shift Type	Mechanical Powershift Control			
Pressure of Transmission	1.1-1.5MPa			
Torque Converter Type	Single-stage Single-turbine 3-element			
Torque Ratio	3.2			
Axles	Rigid Front Axle & Oscillating Rear Axle			
Rear Axle Oscillation (°)	±10°			
Differential	Conventional			
Main Reducer	Spiral Bevel 1-stage Reduction			
Final Reducer	Planetary Reduction			
Tire	17.5-25L-312PR TT			
Travel Speeds				
Forward	7	12	24	36
Reverse	8.5	28		

BRAKES SYSTEM

Service Brake	Single Circuit Caliper Dry Brake
Setting Pressure	0.70-0.78MPa
Parking Brake	Flexible Shaft Controlled Caliper Brake
Emergency Brake	Flexible Shaft Controlled Caliper Brake

STEERING SYSTEM

Type	Hydraulic Load Sensing System
Pump	Gear Pump 246L/min • 2200rpm
System Pressure	14MPa
Cylinder	Type: Double Acting
Bore x Stroke	2-80/315mm
Steering Angle	±35°

HYDRAULIC SYSTEM

Type	Mechanical Shift Control
Pump	Gear Pump 246L/min • 2200rpm
Control Valve	2 Spool (Bucket & Boom)
System Pressure	16MPa
Cylinder	Lift Cylinder: 2-125/84mm
No.-Bore x stroke	Tilt Cylinder: 1-140/53mm
Joystick Control Pressure (Optional)	2.5MPa
Cycle Time (Sec)	Raise: 5.5, Dump: 1.3, Lower: 3.7, Total: 10.5

SERVICEREFILL CAPACITY

Fuel Tank (L)	200L
Hydraulic Tank (L)	150/155 (3rd Spool for Auxiliary Function) L
Crankshaft (L)	17L
Transmission (L)	36L
Front Axle/Rear Axle (L)	18.5L/18.5L

STANDARD EQUIPMENT

WEICHAI Engine	Mechanical Shift Control
4F/2R LONKING Transmission	Standard Lift & Bucket (1.7m)
Mechanical Powershift Control	ROPS & FOPS Cabin
LONKING Axles	Mechanical Instrument Panel
Flexible Shaft Controlled Caliper Brake (Parking Brake)	

OPTIONAL EQUIPMENT

Joystick Control	High Lift & Additional Counterweight
3F/3R LONKING Transmission	Quick Hitch Coupler
Air Conditioner	Quick Hitch Bucket 1.7m ³
Radio/MP3	Bucket (2.0m)
Cold Starting (-35)	Enlarged Bucket (2.3m)
Oil-bath Air Filter	Coal Bucket (2.5m)
17.5R25 11J L-3 TL	Bucket (3 Piece Cutting Edges)
3rd Spool for Auxiliary Function	Log Grapple
3-lever Control for Lift & Tilt & Auxiliary Function	Grass Grapple
Sliding Cabin Window	Side Tip Bucket
Electric Heating Rear Window	Log Fork
Lockable Oil Tank Cap	4in1 Bucket (Quick Hitch Only)
Rear View Camera	Snow Blade (Quick Hitch Only)
Pressure Testing Connector	Close Sweeper

LONKING 龙工

Efficiency Rules the Future

LG833N/CDM833 WHEEL LOADER

POWERFUL WEICHAI DEUTZ ENGINE
LONKING TRANSMISSION
LONKING AXLES
ROPS & FOPS CABIN
VARIETY WITH ATTACHMENT
CONVENIENT MAINTENANCE



■ RATED POWER:	92kW/2200rpm
■ BUCKET CAPACITY:	1.7 m ³
■ RATED PAYLOAD:	3000kg
■ OPERATING WEIGHT:	10300kg

For more information on Lonking products,
Please contact our local agent:

Specifications and design are subject to change without prior notice.
Machines shown may not include optional accessories.